

# User Manual

## EFM<sup>®</sup>51 WALKING TEST KIT

**Art.-Nr.: 7100.EFM51.WT**



## ■ Scope of Supply

- Electro field meter EFM<sup>®</sup>51 incl. 2 distance guides (2 cm)
- Conductive CPS-base
- Voltage head MK 51
- Hand probe & measuring cable (WT-function)
- Grounding cable 0.5 m and 1 m
- Alligator clip
- 2 pcs rechargeable battery 9V
- Battery charger
- Conductive carrying case
- User manual available for download ([www.warmbier.com](http://www.warmbier.com))
- Calibration certificate „German / English“

## ■ Description - EFM<sup>®</sup>51

The EFM<sup>®</sup>51 is a small hand-held Electrostatic Field Meter with digital display designed to measure electrostatic surface potentials and fields according to the field mill induction principle.

- The instrument measures the electrostatic voltage potential. A microcontroller calculates the field strength (V/m) with the pre-selected distance (1 cm, 2 cm, 5 cm, 10 cm and 20 cm).
- In “E-Field meter” mode, the instrument displays the field strength in “kV/m”.
- In “Max. Value” mode at a test distance of 1 cm, the highest and lowest value will be stored.

The induced charge caused by the electrical field, generates a current proportional to the electrical field strength. The selective, parametric operating-amplifier measures the current without affecting the averaged time.

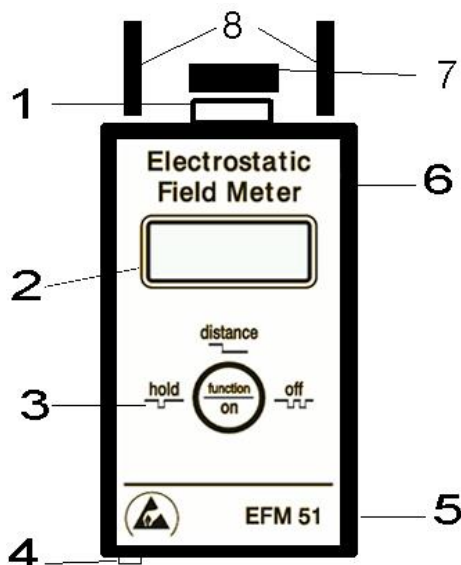

1. Rotating chopper
2. LCD – Display (2 x 12) alphanumeric
3. Function/on key
4. Grounding Socket (4 mm)
5. Battery compartment (back-side)
6. Zero adjustment trimmer
7. Protection cap
8. Distance guides 2cm

## ■ Measurement Principle

The induced charge caused by the electrical field, generates a current proportional to the electrical field strength. The selective, parametric operating-amplifier measures the current without affecting the averaged time.

## ■ Technical Data

<b>Dimensions:</b>	70 x 122 x 26 mm (W x L x H)		
<b>Weight:</b>	130 g (without battery)		
<b>Power Supply:</b>	9V-Alkaline monoblock battery IEC 6F22 or rechargeable NiMH battery		
<b>Measurement Range:</b>	Distance 1 cm →	0.... 8 kV	max. resolution 1 V
	Distance 2 cm →	0.... 16 kV	max. resolution 2 V
	Distance 5 cm →	0.... 40 kV	max. resolution 10 V
	Distance 10 cm →	0... 80 kV	max. resolution 10 V
	Distance 20 cm →	0... 160 kV	max. resolution 20 V
	E-Field meter →	0... 800 kV/m	max. resolution 0,1 kV/m
	CPS Mode →	± 1000 V to ± 100 V	max. resolution 0,1 sec.
	Max. Value 1cm →	± 0... 4 kV	max. resolution 1 V
<b>Display:</b>	2 lines, 12 digits alphanumeric LCD display		
<b>Operating Time:</b>	App. 10 hours at continuous operation with an 9V Alkaline battery		
<b>Adjustment:</b>	Within a plate capacitor's homogeneous field, plate size 200 mm x 200 mm, distance between both plates is 20 mm, the rotating chopper system is centered in the grounded plate.		

## ■ Warranty

We grant a guarantee of **12 months** if handled correctly in accordance with the user manual. This does not apply to the 9V block battery.

**The warranty expires in the event of mechanical damage to the electric field meter and/or unauthorized opening of the device!**

## ■ Operation

- Press the „function/on“ key “shortly” to switch on the instrument.
- Press the key twice while in measuring mode to switch off the instrument.
- Remove the protection cap before a measurement.
- The unit will switch off automatically when the „function/on“ key was not pressed for app. 4 minutes (in CPS-Mode app. 18 min.).

## ■ Hold Function

- The hold-function freezes the display with the actual measured value.
- Press the „function/on“ key “shortly” while in measuring mode for “hold”.
- Press the key while in “hold” to return to measuring mode.

## ■ Measuring Ranges

### 1. Measurement of electrostatic voltages

When the device is switched on, the measuring distance is set to 2 cm (= distance with distance guides). The measuring device should be held at the set distance in front of the object to be measured. If the surface potential is very high or the surface is very rough, the measuring distance should be increased.

### 2. E-Field meter mode

The instrument indicates the field strength in V/m for the current position.

## ■ Measuring Distance / Measuring Mode

Press and hold the „function/on“-key (approximately 2 seconds) until „change cm“ will appear. The pre-selected distance in cm is displayed in the first line. Pressing the „function/on“-key changes the measuring distance.

**2 cm => 5 cm => 10 cm => 20 cm => E-Field meter => CPS-Mode => Max. Value => 1 cm**

After selecting the desired distance or mode, the instrument switches back to measuring mode if no key is pressed for a certain time.

### **Important!**

The measuring range is preset to 2 cm distance each time the instrument is switched on!

The instrument measures the field strength in V/m and calculates the voltage using the selected range:

Display value (V) = Field strength (V/m) x Distance (m)

i.e.. Display value= 1000 V Distance= 10 cm → 1000V = 10.000 V/m x 0.1 m

In “E-Field meter” mode the instrument displays the field strength in “kV/m”.

## ■ Distance Guides

The instrument is supplied with two 2 cm distance guides which are fitted on the front plate.

## ■ Display

The alphanumeric Liquid Crystal Display (LCD) consists of 2 lines of 12 digits each. The measured distance in cm or the measuring mode is displayed in the first line, while the test result is displayed in the second line. An „overflow!“ indication requires to increase the distance.

## ■ Battery Control

The EFM<sup>®</sup>51 has a permanent battery-voltage-control. If the battery voltage drops below 7.5 V a „Low Battery“ warning is displayed and the 9V-monoblock battery must be replaced!

In case the battery voltage drops below 7.0 V the instrument switches off with „auto off“ message to avoid total discharge and acid leakage.

### **Note: Please use Alkaline or Lithium 9V Batteries only!**

If rechargeable batteries are preferred, please use a suitable battery charger for charging the battery separately and follow the manufacturer’s instructions.

### **ATTENTION!**

Do only use alkaline 9V-monoblock batteries respectively NiCd or NiMH rechargeable batteries.

If rechargeable batteries are preferred, please use a suitable battery charger for charging the battery separately and follow the manufacturer’s instructions.

## ■ Grounding

The EFM<sup>®</sup>51 must be connected to ground to allow accurate voltage levels and polarity measurements. Use the grounding socket (4) for ground connection. The unit housing is conductive and the instrument may be grounded through the operator if he is at ground potential.

## ■ Zero Adjust

In general zero adjustment is not necessary. However the trimmer (6) can be used for zero adjust if the instrument does not indicate U=000 or U=00X when the rotating chopper is shielded by the protection cap. The last digit can be ignored, as it is much lower than the specified tolerance.

## ■ Maintenance

**It is very important not to touch any parts of the rotating chopper!**

The sensor head must be free of dust and humidity. If needed, the rotating chopper can be cleaned with alcohol and a lint-free tissue, when switched off.

***Deforming the rotating chopper will damage the instrument!***

## ■ Replacing the Battery

Replace the 9V-monoblock battery when "Low Battery" appears on the display. Please switch off the unit before opening the battery compartment. Remove the battery and carefully disconnect the contact-clip. Plug the contact-clip onto the new battery and put it back into the compartment; then close the compartment.

## ■ Warning

- The unit is not approved for usage in explosive areas!
- The usage in power plants is not allowed!
- This unit cannot measure alternating fields > 1 Hz!
- The Instrument must be grounded when high electrostatic charges are present.
- Sparking on the modular system can cause damage to the unit and need to be avoided.

The first measurement must be carried out at a sufficiently large distance so that the maximum surface potentials can be determined from a safe measuring distance.

## ■ Description - EFM<sup>®</sup>51 / WT

The Voltmeter Set extends the Electrostatic Field Meter EFM<sup>®</sup>51 to a Walking Test Kit.

The Voltage Head **MK51** (Part No.: 7100.EFM51.WT.MK) extends the instrument to a voltmeter with input impedance of  $10^{16}$  Ohms which allows body voltage measurement of up to 4 kV in 1 cm mode or MAX mode.



**Important:** Only voltage up to 4 kV can be measured!

**Please pay attention to the general information regarding high voltage!**



**Important:**

The voltage head MK51 must be calibrated together with the related EFM51 instrument.

## ■ Technical Data

### Voltage head MK51

**Dimensions:** 80 x 40 x 37 (W x L x H) mm  
**Weight:** app. 80 g  
**Measurement voltage:** max. 4 kV

### Hand probe (according to IEC 61340-4-5)

**Dimensions:** app. 75 x  $\varnothing$  25 mm  
**Weight:** app. 100 g  
**Surface:** galvanized

## ■ Preparation for Measurement

Following steps are needed to prepare the setup:

1. Put the EFM<sup>®</sup>51 instrument into the conductive base.
2. Replace the 20 mm distance guides by the (4) 28 mm bolts.
3. Screw up the voltage head MK51 (5).
4. Connect the hand probe with the yellow measuring cable to the measuring head input (6).
5. Connect the CPS socket or grounding socket (1) to ground.
6. Switch on the EFM<sup>®</sup>51 and wait until «Dist = 2 cm» is displayed.
7. Press and hold the button «function/on» (2) until «change cm» appears.
8. Press «function/on» multiple times until «MAX-Mode» is displayed.
9. Wait 2 seconds for MAX-Mode to become active.
10. The setup is ready for use now.

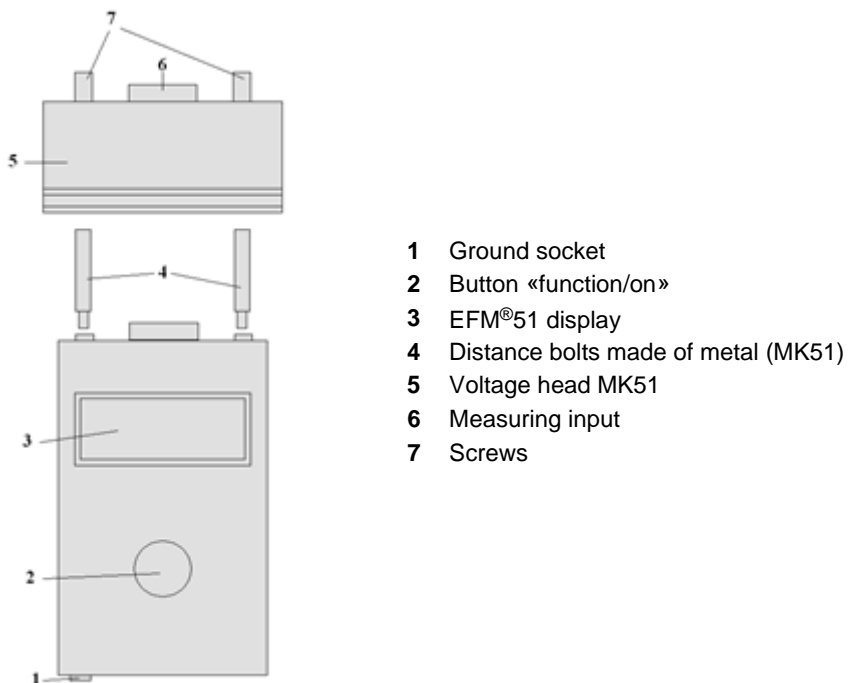

## ■ Measurement

1. Pressing «function/on» the MAX values are reset.
2. Hold the hand probe and perform the walking test.
3. The upper display line indicates the positive and negative maximum values.
4. The lower line indicates the current voltage.
5. Pressing «function/on» freezes the MAX values.
6. A new measurement can be started now.

## ■ Device return and environmentally compatible disposal

This instrument complies with IEC 63000:2016 (Restriction of the use of certain hazardous substances [RoHS]).

This device complies with the requirements according to category 9 of the ElectroG (monitoring and control instruments).

We identify our electrical and electronic devices in accordance with WEEE 2012/19/EU and ElektroG with the symbol shown to the right per DIN EN 50419.

These devices may not be disposed of with the trash.

Please contact our service department regarding the return of old devices.



If you use **batteries** or **rechargeable batteries** in your instrument or accessories which no longer function properly, they must be duly disposed of in compliance with the national regulations.

Batteries or rechargeable batteries may contain harmful substances or heavy metal such as lead (Pb), cadmium (Cd) or mercury (Hg).

The symbol shown to the right indicates that batteries or rechargeable batteries may not be disposed of with the trash, but must be delivered to collection points specially provided for this purpose.



Pb Cd Hg